

# SPORE

Designed By  
Chris Doughty

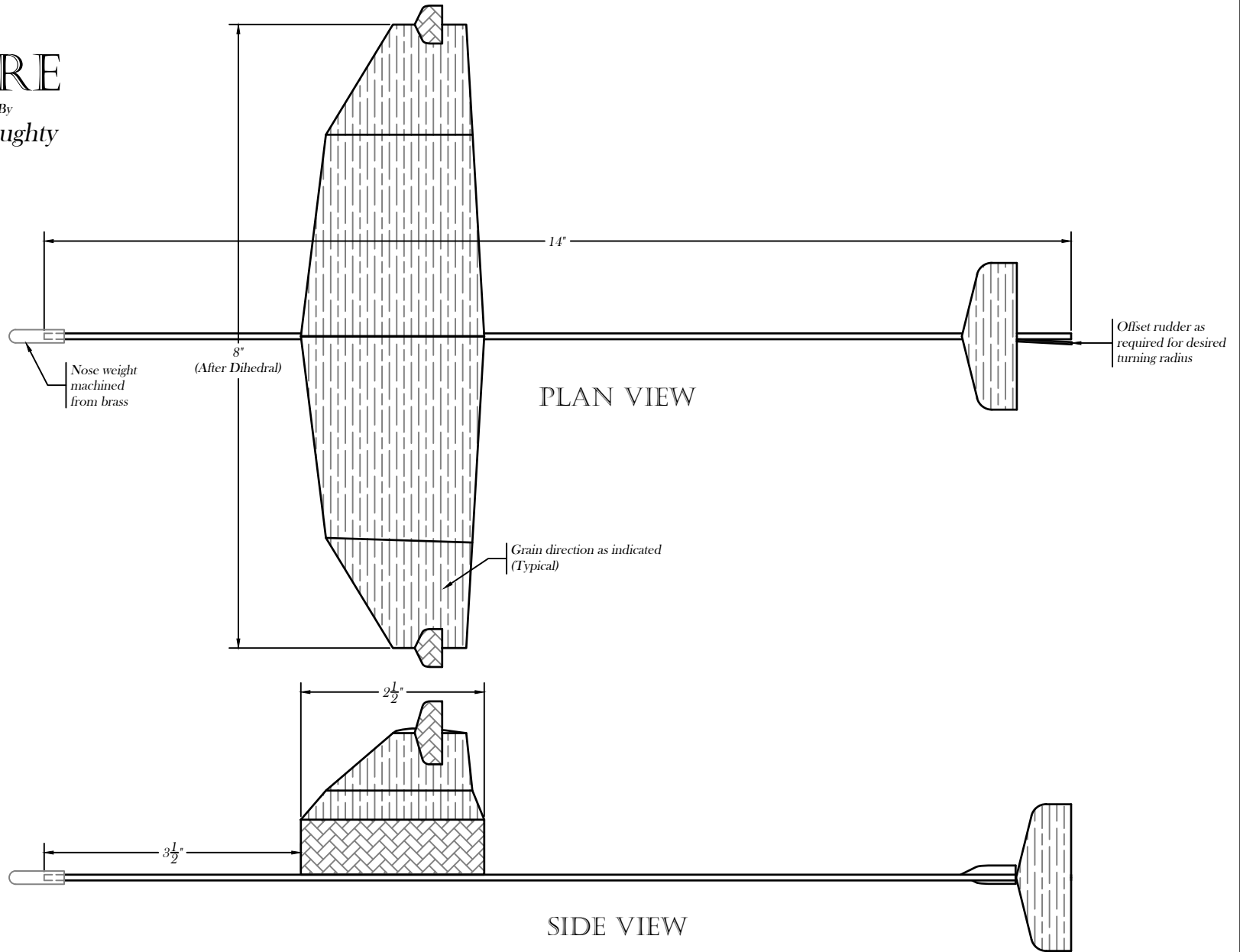

## NOTES

1. See drawing HLG-02 for all full-sized details.

## REVISIONS

NO.	DATE	DESCRIPTION	NO.	DATE	DESCRIPTION
0	03/15/2022	Original			

## SCALE

1:2

March, 2022

## TITLE

8" HAND  
LAUNCH  
GLIDER  
LAYOUT

## DRAWING NO.

HLG-1

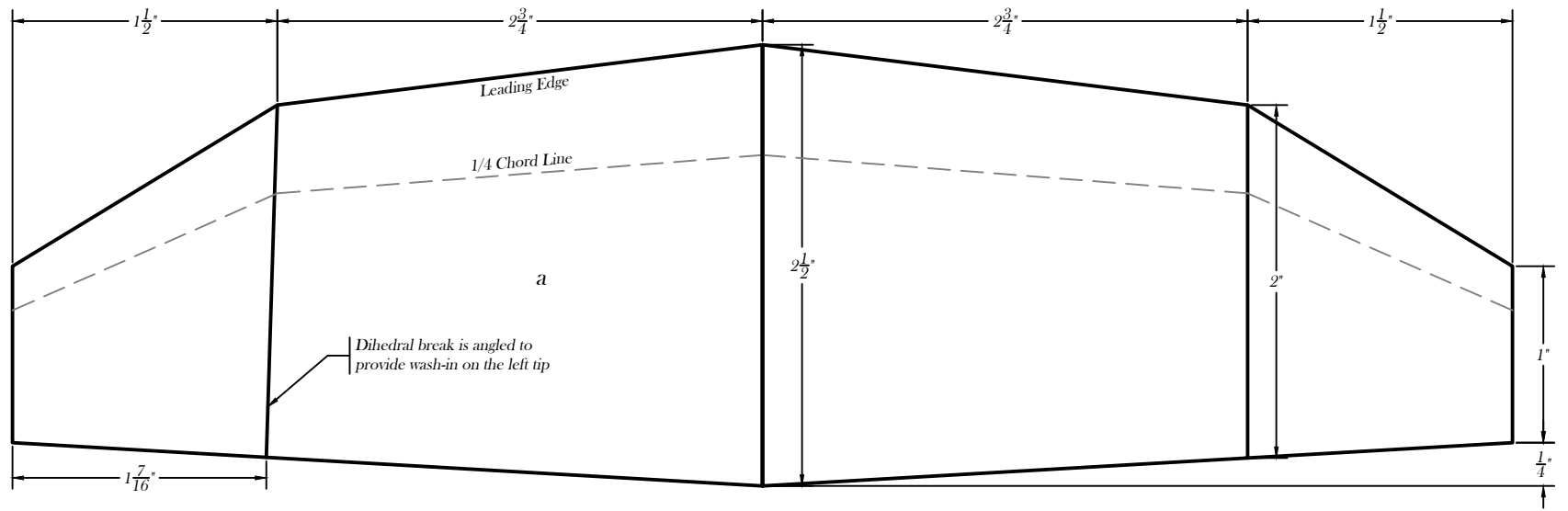

MAIN WING PLAN  
SCALE: 1:1

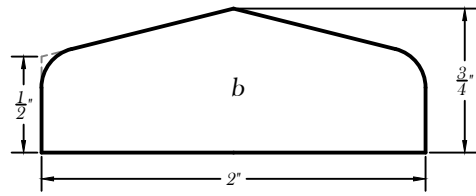

H. / V. STAB PLAN  
SCALE: 1:1

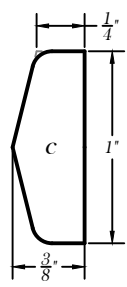

WING TIP PLAN  
SCALE: 1:1

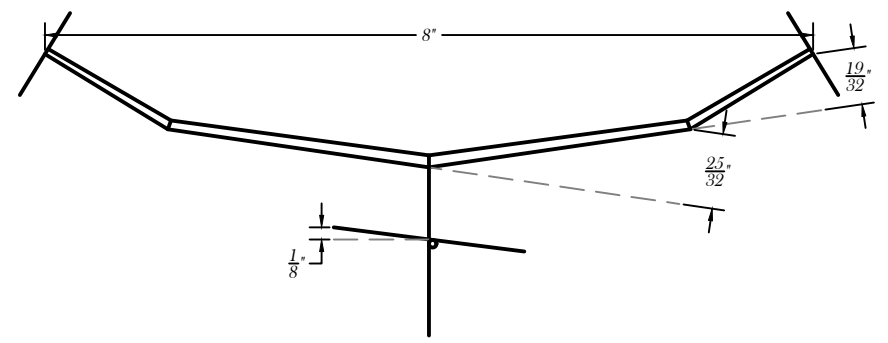

DIHEDRAL DETAIL  
(REAR VIEW)  
SCALE: 1:2

NOTES

- Materials as follows:
  - 1/8" light balsa sheet
  - 1/32" medium balsa sheet
  - 1 ply carbon fibre
- Glue wingtips on with CA glue, and fillet with epoxy to allow to allow for tip-launches.
- Glue pylon (c) on with CA glue, and fillet with epoxy.

REVISIONS					
NO.	DATE	DESCRIPTION	NO.	DATE	DESCRIPTION
0	03/15/2022	Original			

SCALE  
AS SHOWN

March, 2022

TITLE

8" HAND  
LAUNCH  
GLIDER  
DETAILS

DRAWING NO.

HILG-2